

EXHAUST NOTES

Official Publication of the

N
O
V
E
M
B
E
R



2010



PRESIDENT'S NOTES

Thanksgiving already - were did the time go. Just in case you have been sleeping, there was a great time at Jamie & Doris Molina last month, several club member made the trip up, secondly was the Houston MG Club Annual Expo at New **La Centerra 23501 Cinco Ranch Blvd, Katy TX** - great turn out and good weather. Special thanks goes out to all the MG players that put this show together, several Healeys, Triumphs lots of MG's. On Oct 23rd was the Jaguar show in Sugarland town square . This Saturday was the Daughter of British Empire Bazaar & All British car show was held at the Fluor in Sugarland. This was a British show bagpipes, great food, beverages, and lots of neat items to purchase for a great cause. Derek Scovell & his wife from the MG club were helping out. Week early was the Jaguar Concourse in Sugarland Square; another great show see pictures below.

Put the Richmond Arms 3rd Wednesday night Toad Club on your radar November 17, 2010, lots of ice-cold adult beverages & good friends - put it on you calendar. Go ahead mark your calendar for the Annual Austin Healey Christmas Party hosted by Kevin & Cheryl Brady in December more info to follow. As you can see October was one active month, lets all come out for breakfast this Saturday PS its election time and you may be nominated so be there if you get my message.

See you at breakfast

Vince Barnell

President

President -Vince Barnell
txhealey@sbcglobal.net

VICE PRESIDENTS

Event Coordinator - Kevin Brady
Kbrady8985 @comcast.net

Tech - Pete Sandy
pasandy@marathonoil.com

Racing - Roger Williams
979-335-7085 jollyroger@ev1.net

Treasurer/Membership - Mike Vecellio
713-467-5997 mvecellio@comcast.net

Delegate - Roger Lowery
281-469-2610 S_lowery@sbcglobal.net

Newsletter Publisher /Circulation
Mike & Anne Johnson
713-664-6445 masprite@sbcglobal.net

Newsletter Editors / Webmaster
Bob and Bonnie Relick
281-350-3516 rrelick@comcast.net

FURTHER INSIDE

<i>Officers/Club News</i>	<i>2 - 3</i>
<i>Blast from the Past</i>	<i>4</i>
<i>British Car Day</i>	<i>5</i>
<i>Project of the Month</i>	<i>6 - 7</i>
<i>Uncorked</i>	<i>8</i>
<i>Jay and Ron</i>	<i>9 - 10</i>
<i>Calendar</i>	<i>11</i>
<i>For Sale</i>	<i>12</i>



**5, 10 and 15 YEAR GCHC
ANNIVERSARIES DURING 2010**

Robert Farlow - 5 years
Larry and Barbara Kennedy - 5 years
Joe and Susan Thompson - 5 years

Rod Browning - 10 years
Bob and Bonnie Relick - 10 years

George Vernau - 15 years

Vendors Corner

This section is for new vendors that you have tried and have had good success with in your dealings related to the Healey cars, related services parts or repairs:

This month vendor is Van Nuys Plating, Inc. 14611 Bessemer St. Van Nuys, CA 91411
PHONE: (818) 785-5885
FAX: (818) 785-4421 <http://www.vannuysplating.com/>

Blast from the Past

I've come across a few old Exhaust Notes Newsletters from 10 - 20 years ago and thought it would be interesting to see what was going on back then as most of us were not members of the club at the time. I'll put a different page up each month. Enjoy - Bob

GULF COAST AREA
AUSTIN HEALEY CLUB OF AMERICA

EXHAUST
notes



PRESIDENT
JOHN BAUER
713-890-4741

VICE PRESIDENT/ACTIVITIES
MIKE JOHNSON
713-664-6445

VICE PRESIDENT/TECHNICAL
DICK SHIELDS
713-640-2538 (H) 641 7300 (O)

TREASURER/MEMBERSHIP
ROGER LOVERT
713-469-2810

NEWSLETTER EDITOR
KEITH & ANN CHANDLER
713-731-9497

HISTORIAN
MALCOLM RUSHWORTH
713-288-6273

MAY 1990

COMING EVENTS

Saturday
June 9th
8:30 a.m.

Breakfast Meeting at the Einsteins Restaurant, 4824 Nett Street at Durham. Our breakfast meeting has become popular what with our new time & new location providing great food & service with a club like atmosphere.

Sunday
June 10th
8:30 a.m. to
9:15 a.m.

SCCA TSD Rally School/Rally @ 3707 Badger Forest Drive. Now is your opportunity to increase your car enjoyment. See the enclosed flier.

Wednesday
June 13th
5:30ish

Mid Week Gathering of Healey Club Members at the Richmond Arms on Richmond Ave. Be sure to mark this on your calendar. No special occasion - Just a Healey get together particularly for those who may have difficulty attending the breakfast.

Sunday
June 17th

SCCA "CONAKER" - A Gimmick Rally (enter & find out what CONAKER means) Starts: Cliff's Old Fashion Hamburgers, SW corner of Hwy 6 & Alief Clodine. Registration: 1 -1:30 p.m. 1st Car Out 2:00 p.m. Fee: \$5.00 per person

Tuesday
June 19th
7:30 p.m.

Meet Ken Smith of Moss Motors at Anheuser Busch Busch hospitality room, 775 Gellhorn. Take I-10 east from downtown, & exit at Gellhorn. Cinema, Slides, & Suds, & plenty of vintage car talk.

**British Motoring Club
New Orleans
21th Annual British Car Day**

Saturday, March 19, 2011

**At Delgado Community College
City Park Campus**

(Orleans Avenue between City Park Ave & Navarre Ave)

On-Site Registration: 9am to noon

Show: Noon to 3 pm

Awards at 4 pm

**All British Cars & Bikes Invited
Spectators Welcome**

(No charge for spectators!)

For more information contact:

Rick Huber (225) 926-6946

Karen Murray (504) 236-7509

Cathy Greensfelder cgreensf@cox.net

Visit our web site: www.bmcno.org

Host Hotel: Hampton Inn – Elmwood

5150 Mounes Avenue, Harahan, LA 70123 (800) 426-7866 / (504) 733-5646
(Ask for special BMCNO \$99 rate, code "BMC", available until 2/26/2011)

NOVEMBER PROJECT OF THE MONTH

FROM MIKE MCPHAIL

Let's talk about some other electrical topics this time. Well, actually I'll talk and you can listen! I pretty much beat the generator subject to death last time, so I will move on to the voltage regulator control box. The repair manual would lead you to believe that these units are adjustable, but that is just a myth. You can tweak the little screws for hours, and never get things right. But if it isn't working you have nothing (much) to lose by looking a little closer. If the battery is not charging and the generator checks okay (see last month's article), the regulator may be suspect.

Before getting too carried away, put the battery on a charger and see if it will take a charge. The state of charge can be checked with a hydrometer. Keep one of these in your tool box. The number of balls that float when the dropper is filled with fluid from the battery will indicate the state of charge. Be sure to rinse the tool thoroughly when finished, as battery acid will make short work of your Levis. Batteries do not like to be discharged, and most will not survive a full discharge more than once. Likewise, old batteries that have been allowed to go dead will rarely take a charge.

Check the voltage of the charged battery...it should be about 12.5 volts. Once you have a fully charged battery installed in the car, start the engine and observe the voltage at the regulator "A" terminal. The reading should be about 13.5 volts at fast idle. An amp meter or volt meter on the dash is the hot set-up. If you do not have one already, consider adding one. The red ignition light will only show that the generator is not charging the battery. Often the system may be over or under charging, without you knowing it. For those of us with an amp meter life is easy. Upon starting the car, the meter will show a heavy charge (about 15 amps) for a short time, then drop back to just a trickle. Turn on the head lights, and the meter should stay in the positive. A volt meter is almost as good, since you can infer that if the voltage is above 13.5 volts, the battery is being charged. Voltmeters that plug into your cigar lighter are an easy way to monitor the system.

Let's say that you have checked for loose connections, have a good battery and generator, but still no charge. Remove the cover on the regulator control box (RB106) and observe the two relays. The relay with the adjustment screw over the contact controls the current to the generator field coils. It may have dirty or burnt contacts. You may wish to measure the gap (to replicate on reassembly), then loosen the lock nut and remove the contact for examination and cleaning. In normal operation, the other relay (the cut-out) will be operated and the regulator relay will be rapidly operating in order to vary the flow of electricity to the field coils. This isn't as obvious as it sounds, and the minimal sparks produced can be better seen in the dark. The maximum current is delivered with the contact closed, so temporarily shorting out the contact may cause the cut-out relay to operate and the generator to charge. If you try this, be sure to have the battery terminal loose, so you can pull it off if (when?) smoke appears!

Occasionally, overcharging is the problem and the contacts have welded themselves together (shorted generator field coil?). Disconnecting the wires from the "D" and "F" terminals (until you can make repairs) will isolate the generator from the system and prevent forest fires.

A few readers will have the three relay RB340 regulator, but the situations are similar. In practicality, new regulators are quite inexpensive, and a replacement is usually the best bet. Keep one in the boot!

NOVEMBER PROJECT OF THE MONTH
FROM MIKE MCPHAIL

Wiring Diagram for Control Box 37290

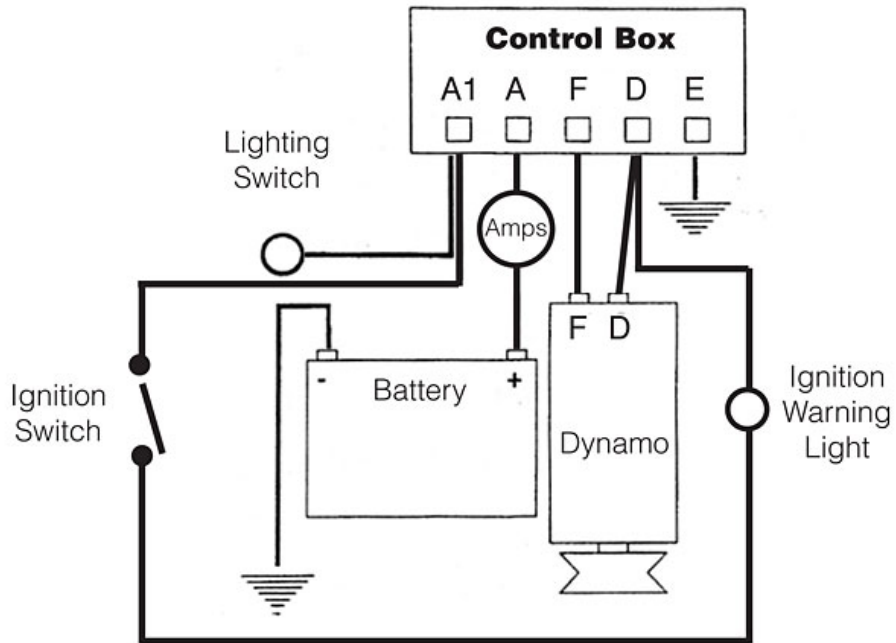

Uncorked 2010

\$44.99 Spec's November Picks on the shelf

From the Winery

The greatest Italian wines come from Tuscany, where winemakers added California and French techniques to their grape growing and winemaking to produce the best of these, known as the Super Tuscan wines. Super T-Rex honors these wines and the Rex family's Italian heritage.

Super T-Rex is a Meritage style wine with an Italian bent. It's a French girl in a Ferrari. It has the forward fruitiness and lovely varietal characteristics of a Sangiovese, with the depth and complexity of a Meritage blend.

Our style is state-of-the-art Californian, beginning with a partnership between grower and wine-maker. We let our grapes get fully vine ripened, then hand pick and hand sort each bunch. The winemaking techniques are gentle and meticulous, resulting in this wine with a brilliant garnet hue, full expression of the fruit flavors, well-integrated oak and layered complexity. The nose and flavors fill every corner of the palate, lingering into a long finish.

Each component wine was fermented and aged separately for the first year. The blend was done at the end of that year and returned to the barrel for a second full year of barrel aging in French and American barrels. The wine is unfinned and coarsely screened at bottling.





Excel Automotive Technology restores, repairs and maintains all types of vehicles for both individuals and businesses. Technicians are ASE certified and I-CAR certified.



Now offering a 10% discount on Moss Parts

Jay Meir

Owner & Member of the Gulf Coast Healey Club

5621 Schumacher Ln
Houston, TX 77057

713-864-6868

www.excelautotech.com



We are located just outside the 610 loop off I-59 and Chimney Rock. From I-59 turn north on Chimney Rock, go 0.2 miles to Schumacher. Turn west on Schumacher, go 0.1 miles. You'll see us on the left





- Mechanical repairs.
- Performance conversions and upgrades.
- Custom exhausts.
- Interiors restored.
- Paint and body.
- Rust repairs.
- Pick-up and delivery services available.

Do-it-yourself Special!!!

10% Discount off Moss Motors parts price plus free shipping to 5R Restorations shop.



BRITISH SPORTSCAR SPECIALISTS

Owned and operated by -

Ron Redding
 (proud member of the
 Gulf Coast Healey Club)
 33803 Pecan Hill Drive
 Brookshire, TX 77423
 281-346-2417

www.5RRestorations.com

GULF COAST HEALEY CLUB

2010 - 2011 Club Calendar

November

- 6 Daughters of British Empire Bazaar & All British Car Show**
- 13 GCHC Monthly Meeting - El Tiempo Cantina**
- 17 Toad Club at the Richmond Arms on Richmond at Fountain View—7:00pm**

December

- 11 GCHC Monthly Meeting - El Tiempo Cantina**
- 16 Toad Club at the Richmond Arms on Richmond at Fountain View—7:00p**
- Christmas Party - Kevin and Cheryl Brady's home**

January

- 9 GCHC Monthly Meeting - El Tiempo Cantina**
- 14 Toad Club at the Richmond Arms on Richmond at Fountain View—7:00p**

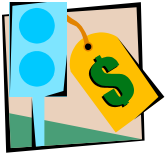

FOR SALE

15" Wire Wheels - REDUCED - SOLD

Set of four 60 spoke painted wire wheels - Small amount of surface rust

No broken or loose spokes - Good spline grooves \$80

Contact- Bob Relick, 713-875-5757, rrelick@comcast.net

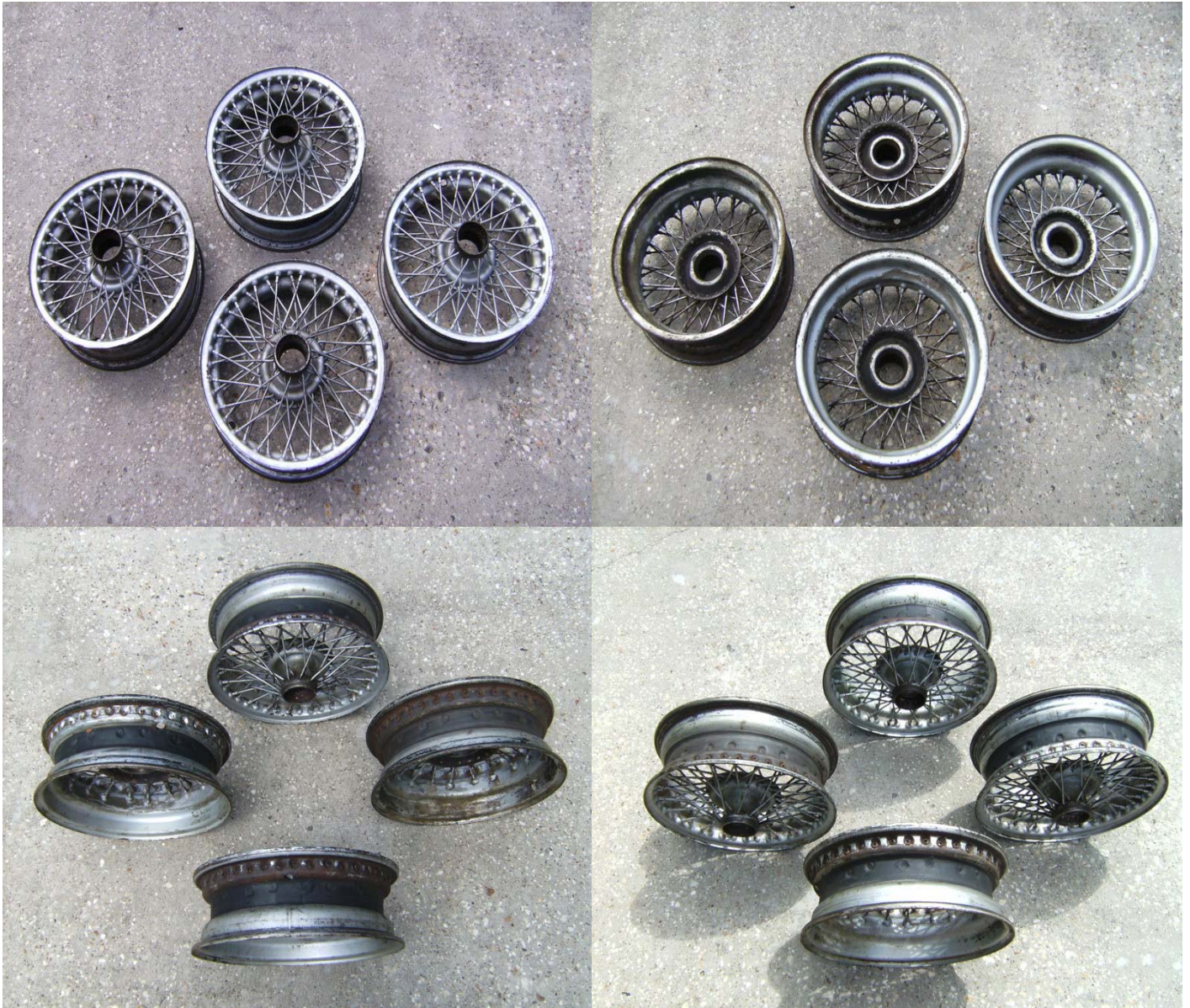

**NEXT MEETING:
SATURDAY,
9:00 AM
NOVEMBER 13
EL TIEMPO CANTINA
5602 WASHINGTON AVE
HOUSTON, TEXAS**



**GULF COAST HEALEY CLUB
Printing & Circulation
Mike & Anne Johnson
4023 Tennyson
Houston, TX 77005**